

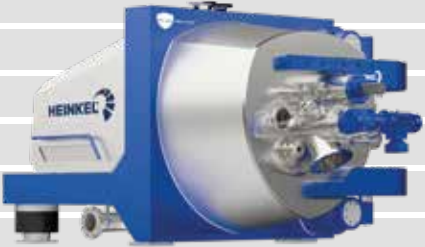

PEELER CENTRIFUGE H 1250 C

Horizontal | Chemical design

High performance for 24/7 multi-purpose or mono-production.

Type	H 1250	
Design	Chemical (C)	
Drum diameter	1,250 mm	
Drum depth	800 mm	
Filter surface area	3.14 m ²	
Filling height	≤ 150 mm	
Capacity	≤ 414 l	
Rotational speed	≤ 1,200 rpm	
G-factor	≤ 1,006 g	
Power main drive / concept	45 KW / direct drive	
Filling load	≤ 518 kg (density up to 1.25 g/cm ³)	
Total weight (empty)	Approx. 17,000 kg (including base plate / foundation) modular for transport approx. 9,000 kg and approx. 8,000 kg	
Dimensions	Suitable for „standard“ truck transport	  

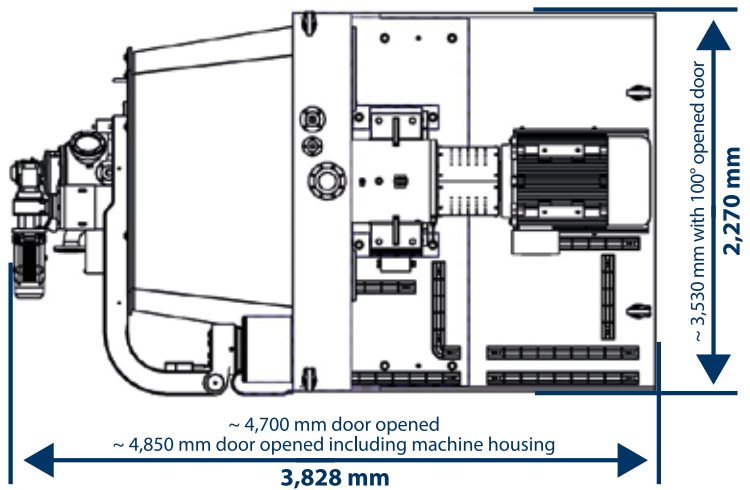
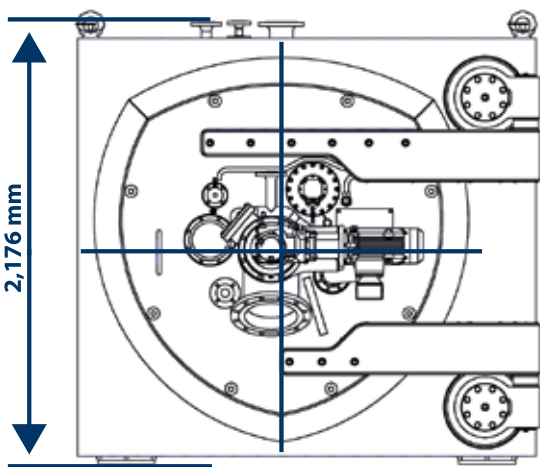

© 2024 HEINKEL | All rights and modifications reserved



HEINKEL Process Technology GmbH
Ferdinand-Porsche-Straße 9
74354 Besigheim | GERMANY

Tel +49 7143 9692-0
info@heinkel.de | www.heinkel.com